

# CON-E-CO LO-PRO<sup>®</sup> SERIES CONCRETE BATCH PLANT



# LO-PRO<sup>®</sup> SERIES

The LO-PRO'S ultra-strong, unitized construction gives this plant tremendous built-in expansion capability!

Dust control systems, unitized cement silos and aggregate storage modules – all may be added to your LO-PRO with simple bolt-on erection. This gives your LO-PRO the ultimate capacity needed for a permanent installation.

And the LO-PRO'S compact base size makes it perfect for enclosing where cold weather or environmental restrictions are an issue.

When you own a LO-PRO, you will never be stuck with a plant your business has outgrown.



## **CUSTOM ENGINEERING**

Over 1,000 LO-PROS are in operation today – all across the nation and around the globe. Yet few are identical.

That's because we custom-engineer each LO-PRO to match your specific needs. Whether bin capacity or configuration, even paint scheme – your LO-PRO is built exactly to your individual specifications.

In addition, the LO-PRO is constantly updated to improve its performance and keep up with changes in the concrete industry. Innovation has made the LO-PRO the industry's top performer... and will continue to do so in the future.

## **THE BEST ACTUALLY COSTS LESS**

When purchasing a batch plant, it's absolutely essential to examine all the costs.

The LO-PRO'S unique design reduces site preparation and foundations. The unitized structure means no welding. Plumbing and wiring are already installed and factory tested, so initial setup is easier, less costly...and you can begin producing concrete sooner.

Even optional expansion bolt-on modules are simple bolt-on installation. And each plant is already built to accept expansion; no modifications are needed later.

Each plant also comes with on-site startup assistance at no extra charge as part of CON-E-CO's ongoing commitment to your satisfaction.

If you were to purchase a plant that did not include these features and benefits, such installation "extras" could amount to tens of thousands of dollars over and above the initial cost of the batch plant itself.

Plus, you need to consider the expected life of the plant. The very first LO-PRO ever built is still in operation today!

When you see the total cost to produce that first yard, your hundred-thousandth yard, or your millionth yard of concrete, there is only one choice. And that's the best: the CON-E-CO LO-PRO.

Every yard of concrete your trucks deliver begins at the same place – your batch plant. Day in and day out, you depend on it to keep you in business.

Your batch plant is the heart of your concrete producing operation. Doesn't your heart deserve the best...the CON-E-CO LO-PRO?

## THE KEY TO PERFORMANCE

Innovative engineering is the key to the LO-PRO'S unequalled performance. And it all begins with our patented, blending cement batcher and the live-bottom aggregate batcher.

This design breakthrough for cement batching allows the LO-PRO to pre-blend cement with fly ash and provide a controlled, consistent, metered discharge into a mixer.

The protruding cement batcher discharge provides 180-degree design access to mixer trucks and the ability to gravity reclaim collected dust directly into the cement batcher.

The live-bottom aggregate batcher delivers precise proportions of sand and aggregate during discharge. The variable speed drive maintains a constant rate of discharge throughout the discharge cycle. And the unique inverted V-trough above the conveyor belt reduces belt wear and excessive starting load.

The LO-PRO'S uniform discharge creates a cleaner discharge, reducing buildup on your truck fins. It also helps you produce more consistent, better quality concrete for your customers.

This unique cement and aggregate batcher design allows us to build a plant that maintains low overall height... without sacrificing discharge height.

The low profile design enables shorter aggregate bin charging conveyors. You may even reach the bins with a front-end loader.

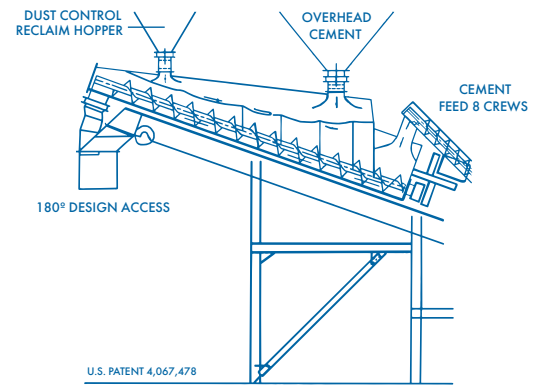

## UNITIZED STRENGTH

The live-bottom batchers also give us the opportunity to construct the LO-PRO as a single, unitized structure. This gives the LO-PRO far greater strength than hinged-style plants, both for transport and operation. Plus, no major teardown and reassembly each time you move to new job sites!

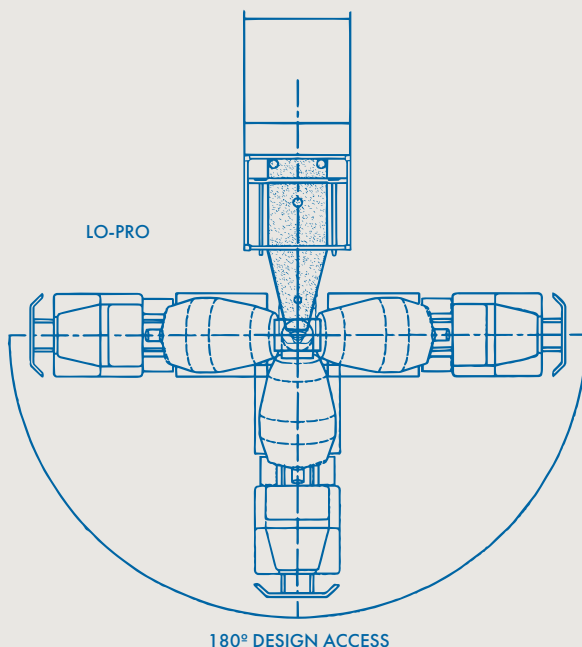

## FAST-CHARGING

The CON-E-CO LO-PRO is one of the fastest charging ready-mix concrete batch plants available. You know how important that can be when you need your trucks out on the road at daybreak – not standing in line at the plant. And you can turn them around again just as quickly later in the day.

Uniform, accurate, pre-blended materials feeding from live-bottom batchers facilitate this efficient charging process. The LO-PRO is truly a complete, performance engineered system, undergoing constant improvement year after year to boost your productivity!



## CAPACITY

- 5- and 12-cubic-yard models available
- Multiple compartments and gates allow more configurations for flexible mix design
- Oversized aggregate batcher
- Available storage modules increase capacity to that of stationary plants

## ON-SITE ADVANTAGES

- Low profile makes bins reachable by front loader
- Conveyors and loaders may approach from either side
- Circuit breakers instead of fuses eliminates costly replacements
- Low pressure, high volume blower cement aeration

## EXPANDABILITY

- Engineered and manufactured for easy, bolt-on expansion
- Stores over 270 yards of aggregate
- Multiple cement silos hold over 2,400 total barrels
- Bolt-on mixer dust control system

## MOBILITY

- Hydraulic self-erect kit eliminates need for crane
- Unitized construction, single weldment structure is stronger for shipment
- Minimal site preparation required
- Hinge-and-pin legs available for easier mobility

## SPEED

- Charges trucks faster than any comparable plants
- 2- To 3-minute cycle capacity
- Live-bottom batchers allow uniform rate of discharge of all materials for faster, more precise charging

## SAVINGS

- Lower erection costs
- Preplumbed, prewired
- Minimal site preparation
- Startup assistance included
- Less time to start producing





  
ASTEC



**ASTEC**<sup>™</sup>

[www.astecindustries.com](http://www.astecindustries.com)